

This Information Is Provided By
CBTricks.com

How to install the Palomar RFX85
on RCI manufactured radios
with EPT3600 series main circuit boards.

Liability of damages to any equipment is the sole responsibility of the user!
Downloading, viewing, or using any information provided on these pages
automatically accepts the user to the terms of this agreement!
Modifications are provided for information purposes only!
Supporters of CBTricks.com paid for the hosting so you would have this file.

CBTricks.com is a non-commercial personal website was created to help promote the exchange of service, modification, technically oriented information, and historical information aimed at the Citizens Band, GMRS (CB "A" Band), MURS, Amateur Radios and RF Amps.

CBTricks.com is not sponsored by or connected to any Retailer, Radio, Antenna Manufacturer or Amp Manufacturer, or affiliated with any site links shown in the links database. The use of product or company names on my web site is not endorsement of that product or company.

The site is supported with donations from users, friends and selling of the Site Supporters DVD's to cover some of the costs of having this website on the Internet instead of relying on banner ads, pop-up ads, commercial links, etc. Thus I do not accept advertising banners or pop-up/pop-under advertising or other marketing/sales links or gimmicks on my website.

All the money from donations is used for CBTricks.com I didn't do all the work to make money (I have a day job). This work was not done for someone else to make money also, for example the eBay CB sellers.

All Trademarks, Logos, and Brand Names are the property of their respective owners.
This information is not provided by, or affiliated in any way with any radio or antenna Manufacturers.

Thank you for any support you can give.

For information on how to Support CBTricks.com
webmaster@cbtricks.com

The user is solely responsible for making sure that any modifications made to the radio unit must meet all Federal and State Regulations or the Country of use! Liability of damages to any equipment is the sole responsibility of the user! Downloading, viewing, or using any information provided on these pages automatically accepts the user to the terms of this agreement! Modifications are provided for information purposes only! Disclaimer: CBTricks.com does not warrant the accuracy of the information contained herein nor is it responsible for any errors or omissions and assumes no liability for the content on this site. While CBTricks.com uses reasonable efforts to include accurate and up to date information, CBTricks.com makes no warranties or representations as to its accuracy or timeliness and assumes no liability or responsibility for any errors or omissions in the content of this site.

RFX85 installation procedure for RCI manufactured 10 meter amateur transceivers (RCI, Galaxy, Superstar, Connex, General, etc.) with the EPT3600 series main circuit board.

- a) Test the transceiver as completely as possible prior to starting any installation.
- b) Turn off the radio and disconnect from all power sources.
- c) If applicable, remove the original heatsink on the back of the transceiver.
- d) Using a 1/8 inch drill bit, drill out the two holes that were used for mounting the heatsink.
- e) Drill one 3/8 inch hole centered between the other two 1/8 inch holes for the wires and coax to run through. It is recommended to drill this hole so that it does not interfere with the mounting of the original finals and driver transistors.
- f) Remove the following components from the transceiver: J77, J98, L31, L52, TR43, TR56, D86, C158, C160, C164, and C209. See Illustration A.
- g) SINGLE FINAL RADIOS ONLY: Locate and unsolder the 560pF capacitor that is 'sky wired' from C209/C171 to J98. Reinstall this capacitor at C171.**
- h) SSB MODEL RADIOS ONLY: Locate C162 and unsolder ONLY the capacitor lead that is closest to the rear panel of the radio. Install a 3.3K ohm, ¼ watt resistor in series with the unsoldered lead (solder one lead of the resistor to the unsoldered lead of C162 and solder the other lead of the resistor to the empty PCB hole of C162).**
- i) Run the wires and coax cables through the 3/8 inch drilled hole. You will need to disassemble the fuse holder in order to fit it through the hole and then reassemble the fuse holder and secure it to the inside of the transceiver – the fuse holder is designed with this in mind and can be easily reassembled.
- j) Mount the RFX85 using the supplied hardware.
- k) RF IN Coax Connections - Solder the center conductor of the RF IN coax to the trace that connects C171 and J98 (#1A). Solder the RF IN coax shield to DC Ground (#1B). See Illust. B.
- l) RF OUT Coax Connections - Solder the center conductor of the RF OUT coax to the trace that connects L31 and C158 (#2A). Solder the RF OUT coax shield to chassis ground (#2B). See Illustration B.
- m) Solder the RED wire to the positive (+) side of the transceiver's DC IN jack (+13.8 volts DC).
- n) Solder the BLACK wire to the negative (-) side of the transceiver's DC IN jack.
- o) Solder the ORANGE wire to the center leg of TR51 (#4). See Illustration B.
- p) Solder the YELLOW wire in the hole for C164 (Positive side). See Illustration B.
- q) Add a ground jumper as shown on the back of VR8 (#5). See Illustration B.
- r) Solder the BLUE wire to positive (+) 8 volts on transmit only (front side of R272) (#6). See Illustration B.
- s) Add a jumper wire at L31 (across the 2 holes where L31 was removed) (#7). See Illustration B.
- t) After confirming that all wires are installed correctly, re-tune the receiver and transmitter as you would normally for the transceiver. **DO NOT SET CARRIER HIGHER THEN 15 WATTS!**

The user is solely responsible for making sure that any modifications made to the radio unit must meet all Federal and State Regulations or the Country of use! Liability of damages to any equipment is the sole responsibility of the user! Downloading, viewing, or using any information provided on these pages automatically accepts the user to the terms of this agreement! Modifications are provided for information purposes only! Disclaimer: CBTricks.com does not warrant the accuracy of the information contained herein nor is it responsible for any errors or omissions and assumes no liability for the content on this site. While CBTricks.com uses reasonable efforts to include accurate and up to date information, CBTricks.com makes no warranties or representations as to its accuracy or timeliness and assumes no liability or responsibility for any errors or omissions in the content of this site.

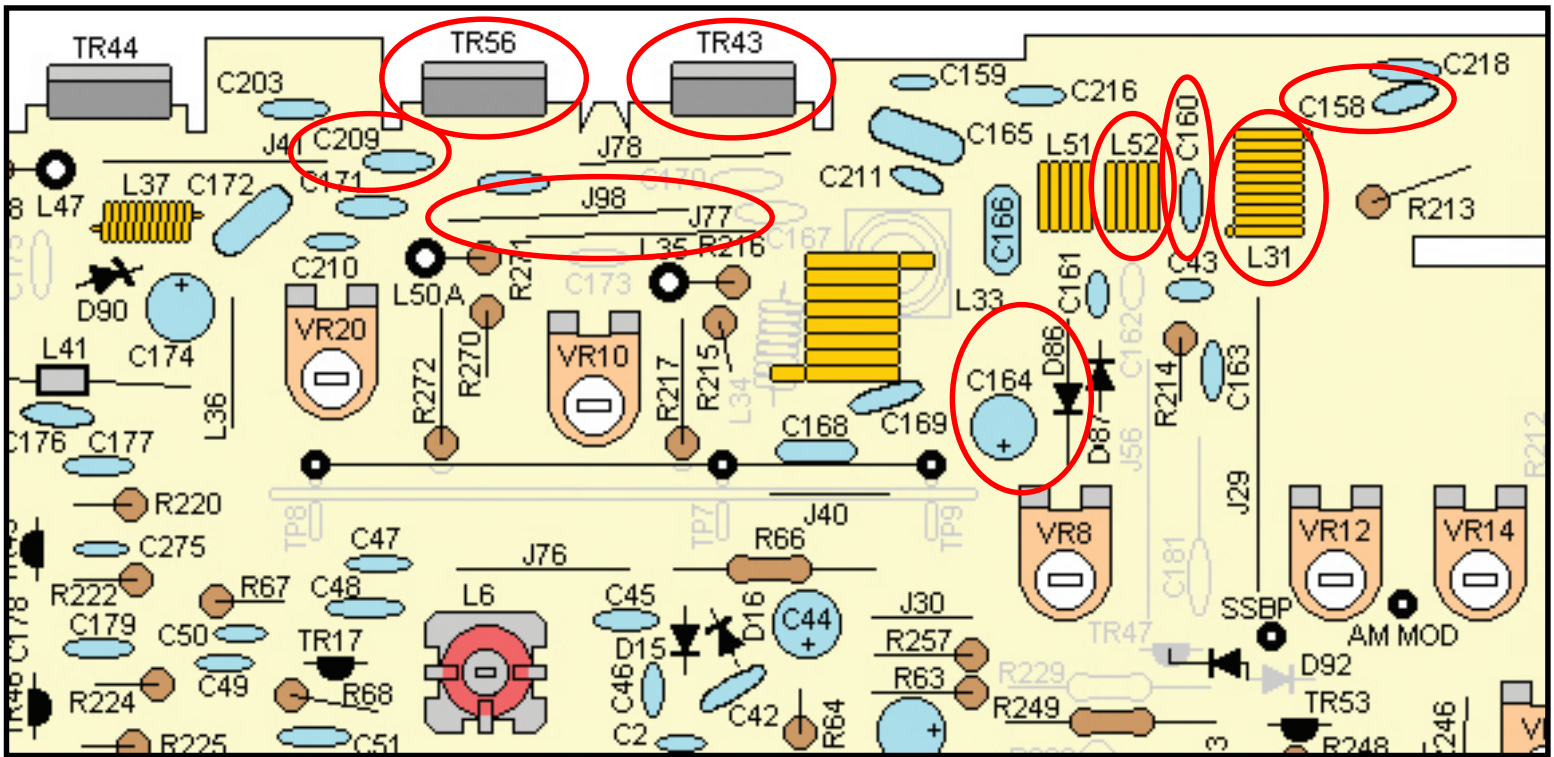

Illustration A – EPT3600* Series PCB
 Circled in red are the eleven (11) parts removed in step f.

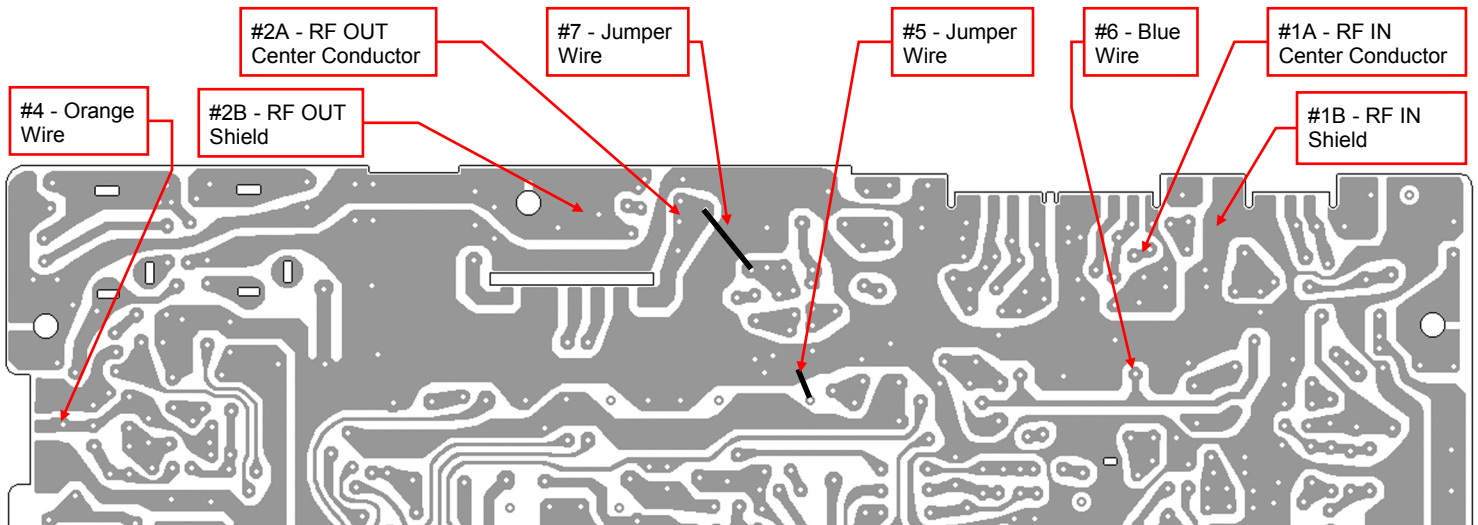

Illustration B – EPT3600* Series PCB Solder Side
 Solder locations for wires in steps l through t.

The user is solely responsible for making sure that any modifications made to the radio unit must meet all Federal and State Regulations or the Country of use! Liability of damages to any equipment is the sole responsibility of the user! Downloading, viewing, or using any information provided on these pages automatically accepts the user to the terms of this agreement! Modifications are provided for information purposes only! Disclaimer: CBTricks.com does not warrant the accuracy of the information contained herein nor is it responsible for any errors or omissions and assumes no liability for the content on this site. While CBTricks.com uses reasonable efforts to include accurate and up to date information, CBTricks.com makes no warranties or representations as to its accuracy or timeliness and assumes no liability or responsibility for any errors or omissions in the content of this site.